



## DVS-SP2

2 Component Fiber sealing system impregnated with PTFE and Silicone free dynamic Run In Lubricant

### Characteristics

- Simple installation
- Use without barrier fluid
- Maintenance free
- Shaft protecting
- No adjusting of gland
- Re-pressurize in operation

### Technical parameters

v [fpm]	1,575
t °F	10 . . . +500
pH	2 - 12
lb/in <sup>3</sup>	0.0397

Pressure Capability is dependent on design of endrings.

### Main application

- Equipment which is badly accessible
- Worn shaft sleeves
- Non centric running shafts
- Pulper

### Suitable for

- Universal use

### Functional description

Due to the special fibre compound and the proprietary lubricant mix, the Sealing Compound System DVS excellently seals stuffing boxes with low pressure. The loose compound will be hold in place by a top and bottom ring, typically made of hydrolysed polyurethane HPU with a special developed geometry. Therefore extrusion of the Sealing compound is prevented and can not cause a premature failure of the DVS Sealing Compound System.

Contrary to braided packing the DVS needs little maintenance only. Due to its loose and pliable structure it is absolutely gentle to the shaft or shaft sleeve surface.

### Accessories

Top and bottom HPU Endrings:

- Material HPU machined according to customer measurement
- Note: HPU is of allround use, please check if other compound is needed due to chemical or temperature in the application.

DVS-Injection Press:

- DVS TP 8200 Spindle Injection Press
- DVS TP 9001 Hydraulic press



Injectionpress DVS TP 9001 for easy reloading with DVS Component P.

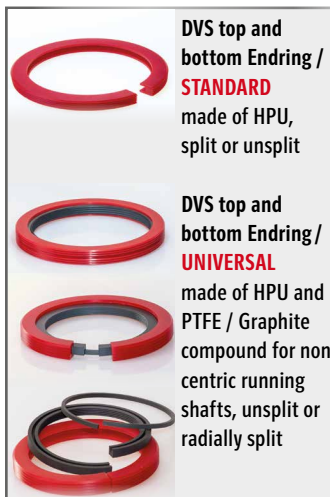

DVS top and bottom Endring / **STANDARD**  
made of HPU, split or unsplit

DVS top and bottom Endring / **UNIVERSAL**  
made of HPU and PTFE / Graphite compound for non centric running shafts, unsplit or radially split

### 2 Component System

Component H:  
Is used for the basic manual fill of the stuffing box.

Component P:  
Is used for Injection with press DVS TP 9001.

### Form of delivery

Unit for H- and P-Type:  
Cans 2 lbs,  
Hobbock of 45 lbs

All technical information and advice is based on our experience and will be given most conscientiously but without any liability.

Indication and figures are for guidance only and need to be examined by the user. All sizes are subject to manufacturing tolerances. We reserve the right to modify specifications at any time. Please note that the technical values cannot be used all at the same time in their maximum values.

## Installation

The DVS system can be installed in standard stuffing boxes. The suitable quantity of DVS compound as well as a top and bottom ring (same geometry) according to the stuffing box cross section is needed.

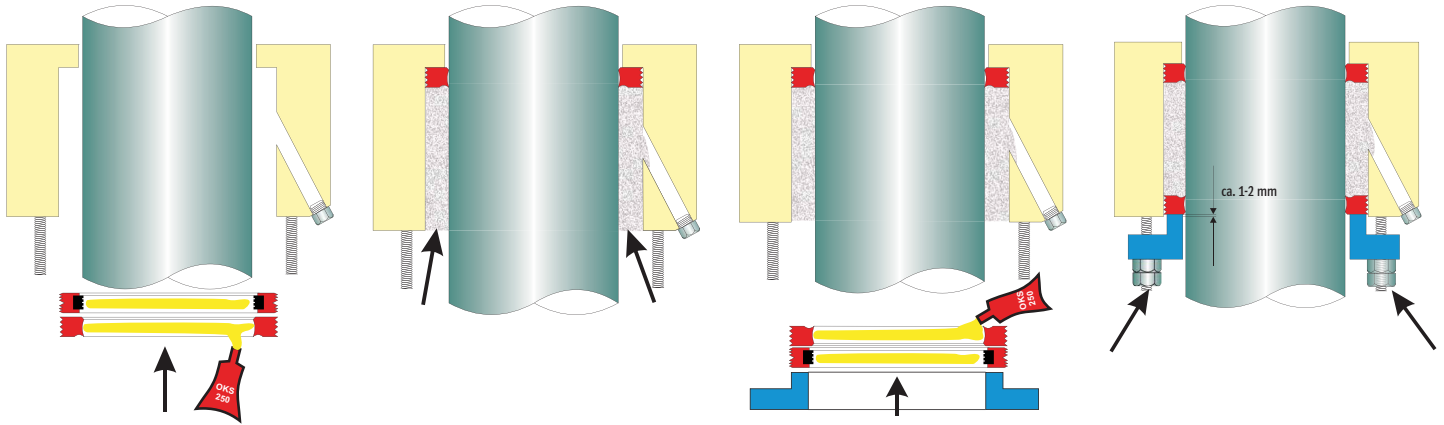

1.) Grease the bottom HPU ring on the interior surface contact to the shaft with a suitable lubricant, for example OKS 250 white paste. Put the bottom ring into the stuffing box, with the seal lip pointing inside the stuffing box and push it fully to the bottom of the stuffing box. For ease of installation in assembled machinery, the top and bottom ring can be cut and after assembly over the shaft it must be glued together on the cutted area with suitable adhesive, example LOCTITE 406.

2.) Fill the stuffing box with the DVS material around the circumference by hand. Put it in equally and pre-set it. The better the sealing compound is pre-compressed at the beginning, the lower is the start up leakage!

Fill the stuffing box to the top.

3.) Grease the top HPU ring with a suitable lubricant, for example OKS 250. Insert the ring with the sealing lip pointing in the stuffing box.

4.) Press the top HPU ring with the gland approx 2 mm in the stuffing box. The gland follower should have a good guidance in the stuffing box. Take care the gland is in an equally levelled position.

**Attention: Secure the gland nut with glue or mechanically by counter nut.**

### Run In Procedure after installation:

1.) Prime the internal cavity space of the machine with product (alternatively use water).

2.) During dynamic application, with turning shaft in operation, press 5 to 15 strokes depending on the total volume of the stuffing box with DVS injection press TP9001. Wait 15 to 20 minutes, let the compression distribute in the stuffing box and control during this time the leakage and heat development. The leakage rate should now be reduced and actually low.

3.) After several days of operation control the leakage again. There should no leakage be visible during operation. When the machine is idle there may be leakage, but only drops without any solids. If so a constant and normal condition is reached. Otherwise repeat actions described in 2.)

4.) Press TP 9001: To move the DVS material with a press, it needs approx. 150 bar

pressure which can be checked on the manometer. Some material may actually need up to 300 bars injection press. The more the stuffing box is filled with DVS material, the slower the pressure drops. Please be assured there is No over pressurisation in the stuffing box! The pressure reading is only in the injection system.

### Maintenance:

Due to small losses the DVS Sealing Compound System can loose a little bit of volume within time. This leads to (increased) leakage. By suitable reinjection (approx. 5 strokes with the TP 9001 press) during operation, this process leakage can be stopped immediately. If it is not possible to reach the sealing performance again or this appears several times per month - stop the equipment, clean the stuffing box and install new sealing compound.

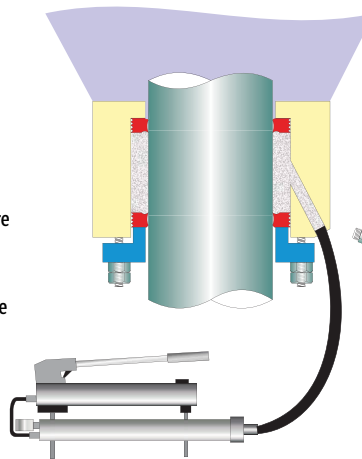

**ATTENTION:  
DO NOT RETIGHTEN THE STUFFING BOX!**



**When leaking, inject more DVS Compound with suitable press during operation**

### IMPORTANT

- 1.) DVS does not operate with barrier fluid at all, therefore the unnecessary lantern ring must not be installed into the stuffing box.
- 2.) DVS must not leak like braided packing. If necessary DVS material can be reinjected until the stuffing box is leak free. The more accurate the radial run out is controlled or the less excentric the shaft is positioned to the stuffing box housing, the better will be the sealing performance.
- 3.) DVS can be reinjected during operation.
- 4.) DVS does not wear shaft sleeves. Therefore uncoated shafts or shaft sleeves of CuZn, ST-steel or special alloy (1.4571. 1.4301 etc.) should be used.
- 5.) DVS can also be used - if no top and bottom rings of HPU or other suitable material, alternatively use pre-compressed packing rings of a suitable quality.
- 6.) DVS should never be adjusted by tightening the gland, otherwise a thermal damage will arise immediately due to the high self compaction.
- 7.) DVS works with limited performance when using it in a cross section of <math><10\text{ mm}</math> (3/8"). In that case discuss with the supplier.